

BMW X1 (E84) 2009 - 2015



Tools Required: _____

- Panel Removal Tool/s
- Screwdriver/s
- Cutting Tools [Dash Modification Required]

DISCLAIMER

This instruction booklet is based on carefully documented data and research. Connects2 cannot be held responsible for discrepancies/inconsistencies that may occur due to automobile manufacturing changes, options, or damage that may occur in the vehicle during the installation of components while using this booklet

STEP ONE

Use a panel removal tool to remove the trim panel from around the air vents, and pull out the air conditioning unit

**STEP TWO**

After removing the unit, disconnect the cables to the vehicle and remove the two circled screws inside the cavity. Now remove the storage locker

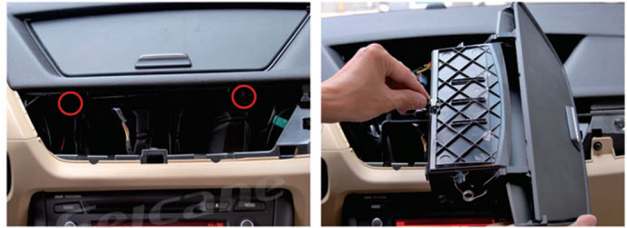
**STEP THREE**

Using a panel removal tool, remove the trim panel from around the gear stick

**STEP FOUR**

Use a panel removal tool to pry the air conditioning panel away from the dashboard. Disconnect all wiring from the panel.



STEP FIVE

Use a screwdriver to remove the two circled screws from behind the air conditioning unit.

Remove the two metal clips highlighted by white squares in the image.

Pull out the vehicle's original head unit and disconnect all wiring.



STEP SIX

Dash Modification Required

Cut out the plastic from inside the dashboard cavity to create space for the new double DIN head unit.

(See section highlighted in red for area to cut away)

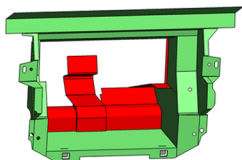

STEP SEVEN

Plug the extension lead into the connection from the vehicle (previously removed from the back of the air conditioning panel in Step Four)

Pull the extension lead up through the hole left by the storage locker



STEP EIGHT

Attach the brackets (2,3) to the air conditioning panel (4) and CT23BM12 button relocation panel (1) as shown, using the four supplied Pozi Pan screws (5)

Make all connections to the panel and mount into the hole left by the storage locker

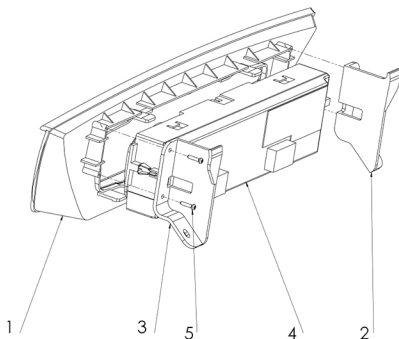

STEP NINE

Attach the brackets (2,3) to the aftermarket head unit (4) using the four supplied Butt Head screws (5). Make all connections to the head unit and place into the dash.

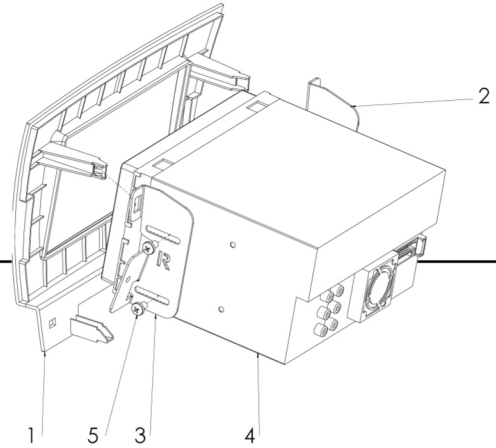
**STEP TEN**

Surround the head unit/bracket assembly with the fascia panel (1) and clip into place using the slots in the brackets as a guide.

STEP ELEVEN

Reinstall all other components in reverse order of disassembly to complete your installation.

