



10. Finally, clip the air vents and clock into position to complete the installation

Notes:

- 1) The installation must be completed with great care.
- 2) Some cables/wiring might need to be extended (depending on model/equipment).
- 3) Metal clips are taken from the OEM stereo.

Part No.: CT23LR03
Piano Black

• Land Rover Defender

Part No.: CT23LR04
Black

Double DIN Navigation

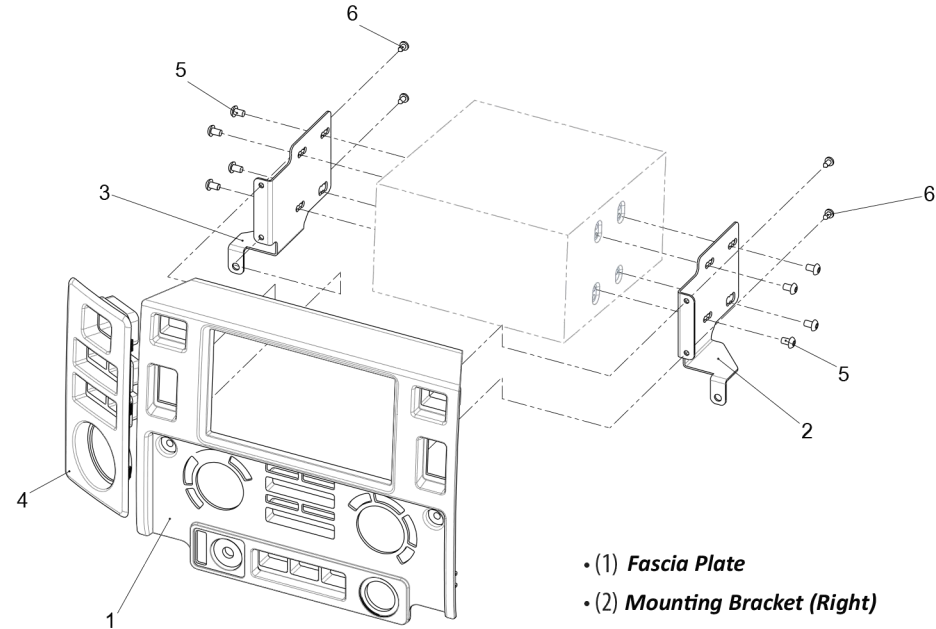

- (1) **Fascia Plate**
- (2) **Mounting Bracket (Right)**
- (3) **Mounting Bracket (Left)**
- (4) **Side Panel**
- (5) **Flat-head Screws**
- (6) **Screws**

powered by

Aerpro
First Choice

Connects 2

MODEL NUMBER - FP9113

Land Rover Defender



1. Firstly, remove the OEM radio using a suitable tool



2. Remove the TX-30 Torx screws



3. Remove the fascia, and then remove any buttons/switches.



4. Separate the air vents from the OEM fascia using a suitable tool

Land Rover Defender

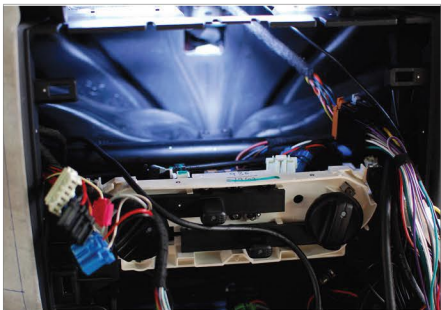

5. Remove the metal clips and reroute the air vent wiring (See image).



6. Measure the side panel and cut the dashboard accordingly.

Put the side panel back in.



7. Install the buttons/switches from your old fascia plate into your new one.

Land Rover Defender

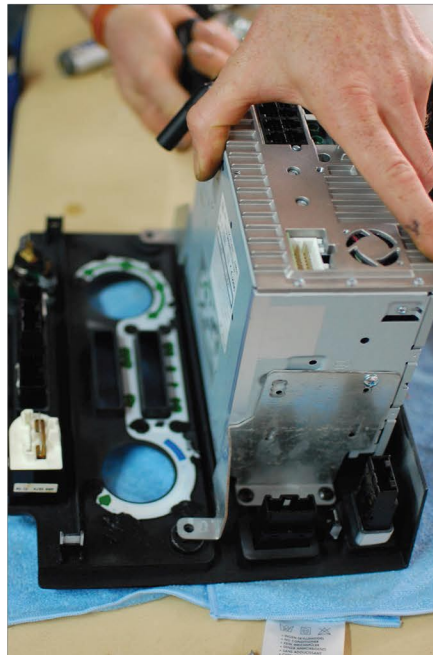

8. Attach the 2-DIN stereo to the mounting brackets and fascia, and screw in place



9. Reinstall the radio and aftermarket fascia plate

Land Rover Defender

Land Rover Defender