

Aerpro[®]

First Choice



SERIES 2

INSTALL KIT FP9550GK & FP9550BK
INSTALLATION/USER MANUAL

Installation Information

PLEASE READ BEFORE INSTALLATION

The system you are installing acts as a controller for your factory Heating/Cooling system.

To ensure correct functionality, please confirm the factory system is functioning correctly prior to installation.

This controller WILL NOT fix any prior issues with the Heating/Cooling system in the vehicle.

To confirm the factory system is operational, follow the steps below.

1. Check Fan speed control
2. Check the Vents change correctly
3. Check the system changes temperature correctly
4. Confirm Dual Zone separates temperatures correctly
5. Air conditioner
6. SWC (The steering controls must be working in the vehicle previously to work with our control harnesses. They will not fix previous underlying problems).

If the system is deemed to be operational, Please continue with your Installation

NOTE: Remove any Cd's in the from the factory head unit before uninstalling

Product and Install Information

If you would like to find more information on this product or download an up to date digital copy of this manual, please visit the aerpro.com website and search for your model or scan the QR code below.

FP9550GK



FP9550BK



An installation and setup video is also available on our site



Tools needed

Use the following tools to make dismantling the car and the installation of the new fascia easier. **NOTE: Do not use power tools, only use the tools recommended below and do not over tighten screws as they may damage the fascia kit. Also take care in removing the vehicles trim as over time they may have become brittle.**

1. Panel Removers

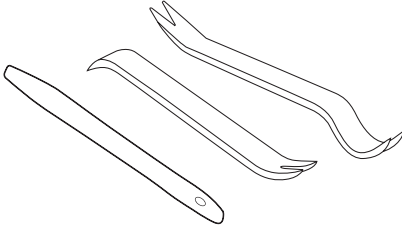

2. Phillips Head Screwdrivers

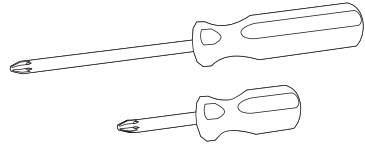

3. Small Flat Head Screwdriver

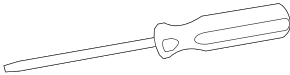

4. Small Pick



5. Side Cutters

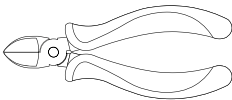

6. Hacksaw or cutting blade

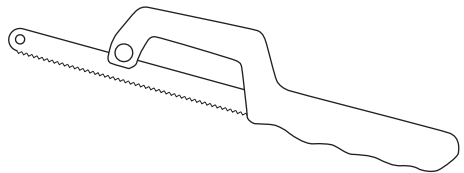

7. Cable Ties

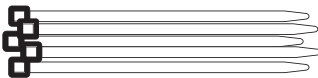

8. Electrical Tape

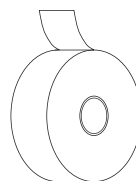

Product overview

The Aerpro FP9550GK/BK VE Series 2 Facia Installation Kit is Australian designed and engineered and has been made for fitting a double DIN aftermarket radio, CD or DVD player to the original double DIN enclosure. The trims between these two models varies as shown below and are model specific.

FP9550GK



FP9550BK



Optional accessory both variants (Sold separately)

The Aerpro AWCGM1 wireless charging dock is also available for this installation



Inclusions

- 1x Double DIN facia kit
- 1x Gunmetal trim panel (FP9550GK) or 1x Piano Black trim panel (FP9550BK)
- 1x Built-in HVAC and SWC unit
- 1x Universal SWC patch lead
- 1x Factory USB retention lead
- 1x Camera retention lead
- 1x Antenna adapter
- 1x Mounting kit
- 2x Support brackets
- 1x User/Install manual



OR

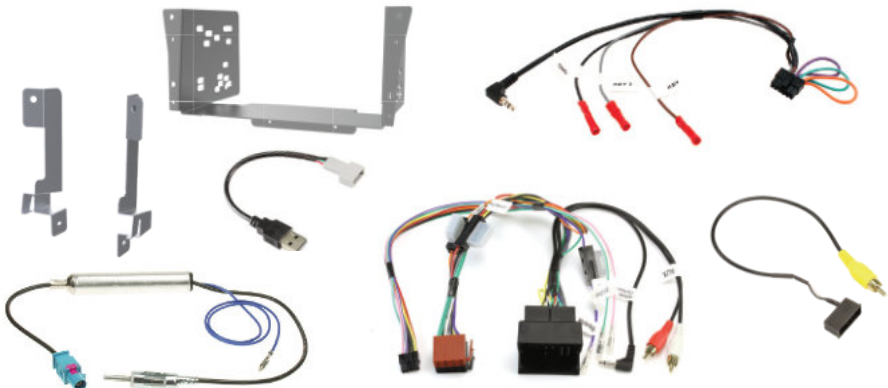

Dash Disassembly

Reset factory HVAC system

It is recommended that you re-calibrated the factory HVAC heater valves or ducting positions before removal of the factory head unit. Press and hold the rear demister for 5 seconds until you hear the actuators re-calibrate. **NOTE: Remove any Cd's in the from the factory head unit before uninstalling**

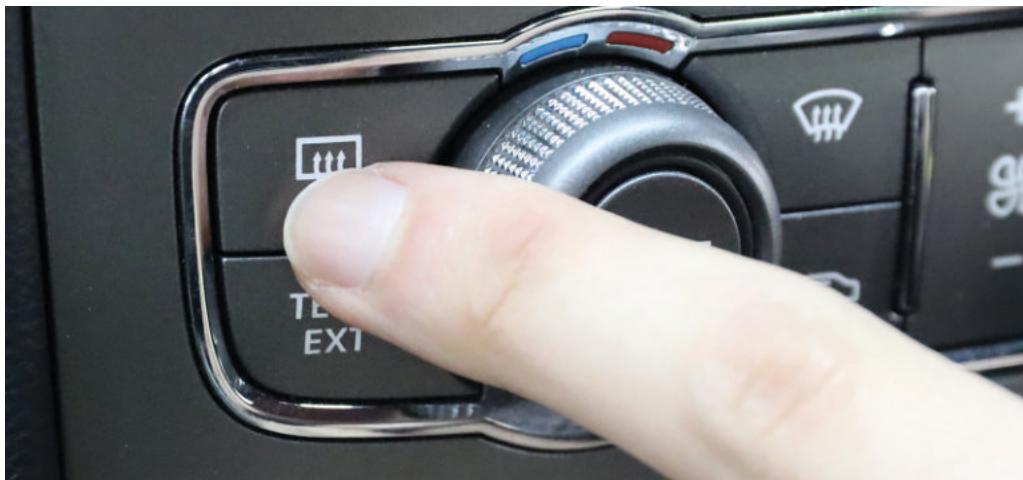

Remove right side dash panel

Insert a panel remover and lever outwards



Dash Disassembly

Remove right side trim

Insert a panel remover and lever outwards



Remove right side trim

Continue to the left side with the panel remover

FP9550GK



FP9550BK



Dash Disassembly

Remove left side panel

Insert a panel remover and lever outwards



Remove left side dash trim

Insert a panel remover and lever towards yourself working your way to the centre of the dash



FP9550GK



Dash Disassembly

Remove glovebox

There are 2 x screws to remove from the bottom of the glove box



Remove glovebox

Unclip the panel underneath the glovebox to access glove box light and mounting screws



Dash Disassembly

Remove glovebox

Twist to remove the glove box light from the panel (Model dependent) and place trim aside until reassembly



Remove glovebox

There are 2 x screws to remove at the bottom of the glovebox as indicated



Dash Disassembly

Remove glovebox

There are 5 x screws to remove from around the top of the glove box. Remove the outer screw covers with the small flat head screwdriver or pick

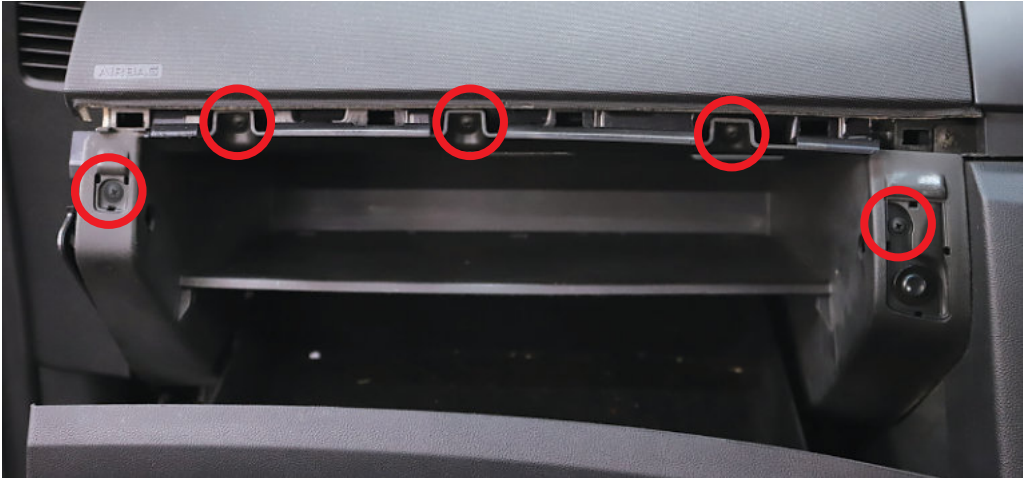

Remove glovebox

Once the glovebox is unscrewed, disconnect the connector at the rear to completely remove the glovebox from the vehicle. The connector sits behind a metal plate with a cutout to access the clip

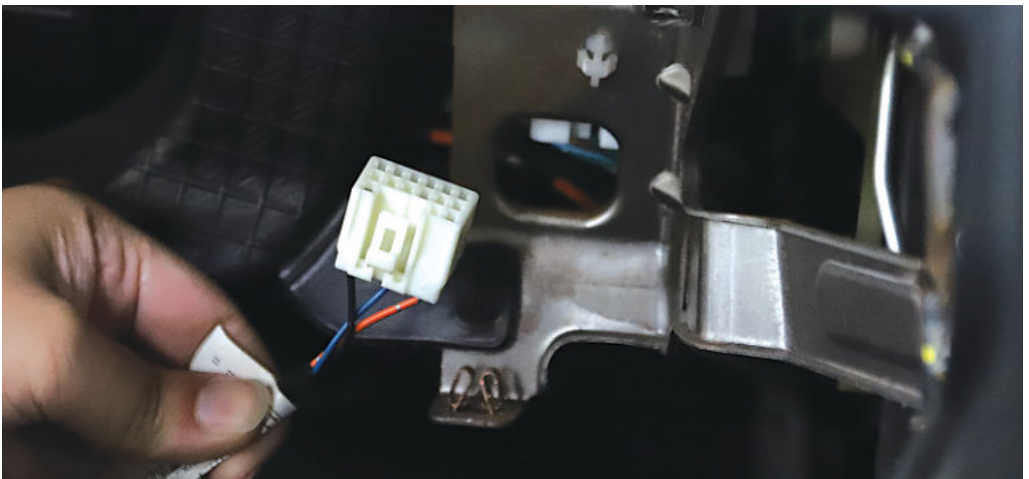

Dash Disassembly

Remove left side center console panels

The panels are held in with 1 plug and 2 inner clips. Release centre of plug and remove. Pull the lower panel downwards and out. Then pull the top panel outwards and downwards to release from the clips.



Remove left side center console trim

Once removed, place the panels aside for reassembly

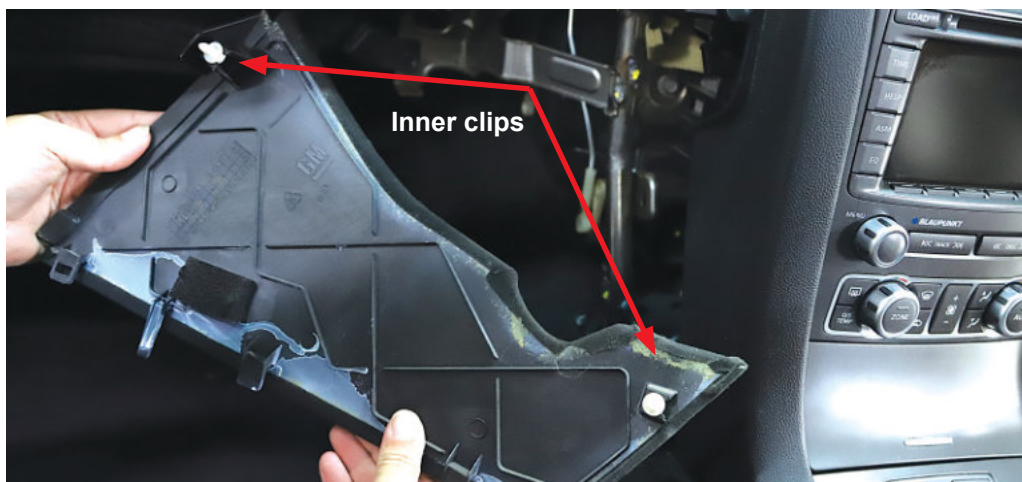

Dash Disassembly

Disconnect Antenna

Disconnect all antenna and USB connectors. Press down on the top of the connector to remove from the head unit



Remove under steering wheel cover

Insert a panel remover and lever towards you to remove the trim, repeat this process on the opposite side.



Dash Disassembly

Remove under steering wheel cover

While unclipping, be sure to hold up the panel and not let it drop to protect the headlight switch connection



Remove right side center console panels

The panels are held in with 1 plug and 2 inner clips. Release centre of plug and remove. Pull the lower panel downwards and out. Then pull the top panel outwards and downwards to release from the clips as done on the left side previously



Dash Disassembly

Remove rear camera plug & quadlock

Unclip the rear camera connector below the quadlock



To remove the quadlock connector, press the sides marked with arrows inwards. The lever will release then pull outwards to detach from the head unit.



Press the sides marked with arrows inwards

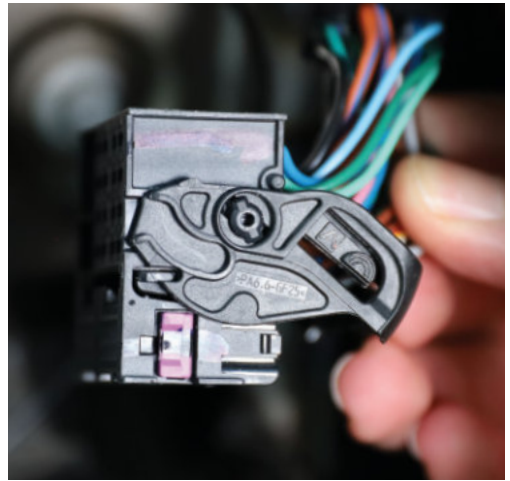

Connector released

Dash Disassembly

Remove centre panel trim (Calais speaker shown)

Use pick tool or flat headed screwdriver to lift panel or grille. Put aside for reassembly



Remove centre panel trim top screws

Unscrew the 2 screws holding the main factory fascia in place

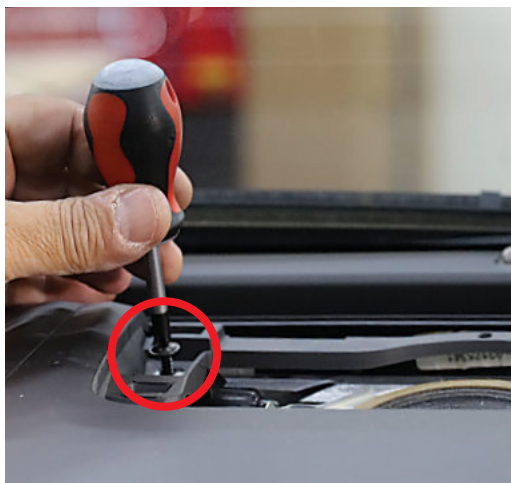

Dash Disassembly

Main factory fascia removal

Unscrew the left hand side screw holding the main factory fascia in place



Main factory fascia removal

Unscrew the right hand side screw holding the main factory fascia in place



Dash Disassembly

Remove centre console trim

Apply the handbrake and place the gear shift in the neutral position. Using a panel remover, lift the trim around the gear stick holding the window controls. Then carefully lift the top by hand to release the retaining clips



Remove centre console trim

Unplug the 3 connectors attached to the centre console trim



Dash Disassembly

Remove pocket if applicable

Unscrew left and right hand side screws and remove



Remove pocket if applicable

Pull upwards and towards you to remove



Dash Disassembly

Remove tray if applicable

Unscrew left and right hand side screws and remove



Remove tray if applicable

Pull upwards and towards you to remove



Dash Disassembly

Remove centre console side panel

Unscrew left and right hand side screws and remove



Remove centre console side panel

Carefully lift the base of the centre console panel up to loosen. Pry the centre top retaining clip with the removal tool then pull the top gently towards you to release all remaining retaining clips



Dash Disassembly

Remove factory screen and dash panel

Hold at the top and base and pull gently forward to remove

FP9550GK



FP9550BK



Remove factory head unit

Unscrew the 4 main screws

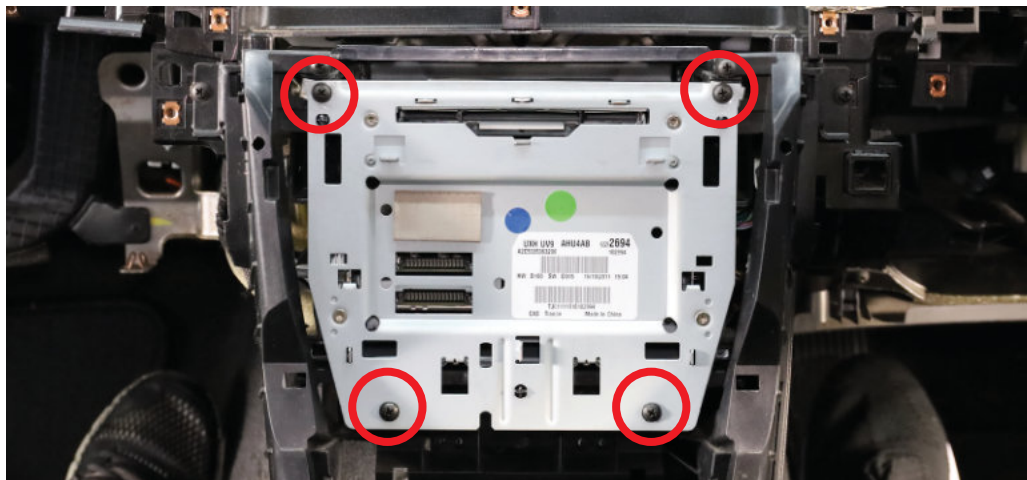

Dash Disassembly

Remove factory head unit and cage

Pull the head unit forward and out to remove to expose the head unit holding cage. The cage is not required in the install. The cage can be removed without removing all of the centre console by cutting away part of the radio support. Remove the 3 screws on the inner cage

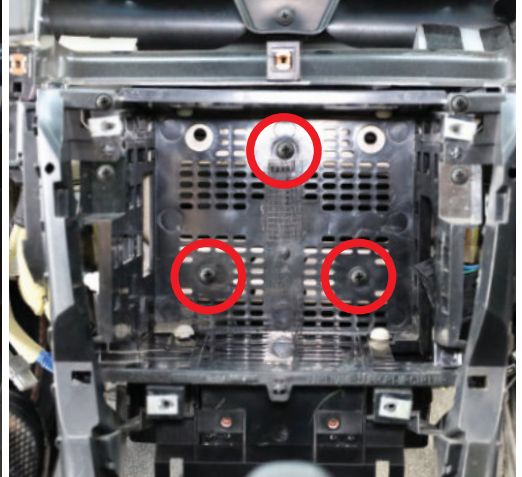

Remove factory head unit cage

Remove the 2 screws on the bottom of the cage

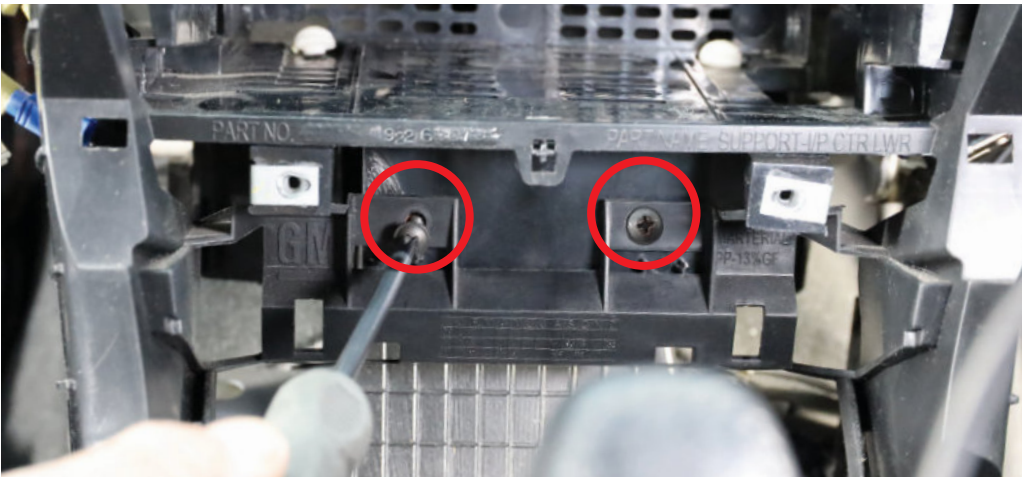

Dash Disassembly

Remove factory head unit cage

Remove the 6 screws on the top left and right sides of the cage trim

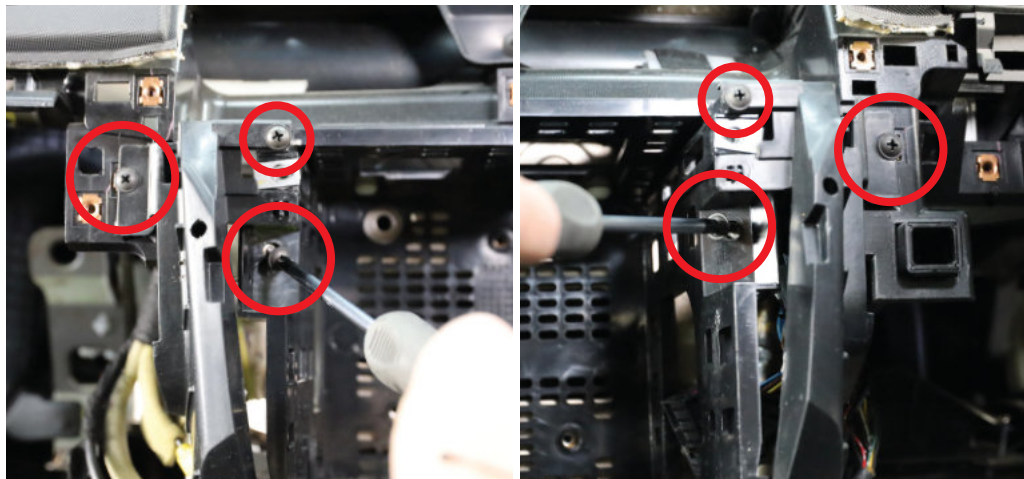

Remove factory head unit cage

To remove the cage and for clearance of the new facia, part of the radio support needs to be cut on each side and removed



Dash Disassembly

Remove factory head unit cage

Once the radio support is cut and removed, the cage will then be able to be removed and is no longer required, ***retain these screws for later use.***

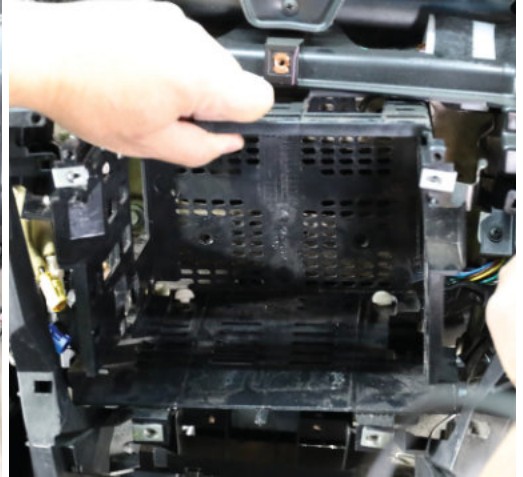
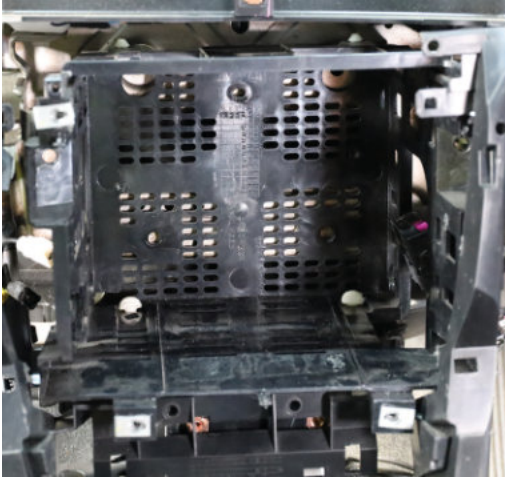

Re-screw factory side trims

Re-screw the trims back in place



Adding ancillary support brackets

Ancillary support bracket positioning

The brackets are designed for re-attaching the side panels to the mounting points that were lost when the cage was removed. Refer page 12 & 37. The brackets attach to the existing mounting locations.

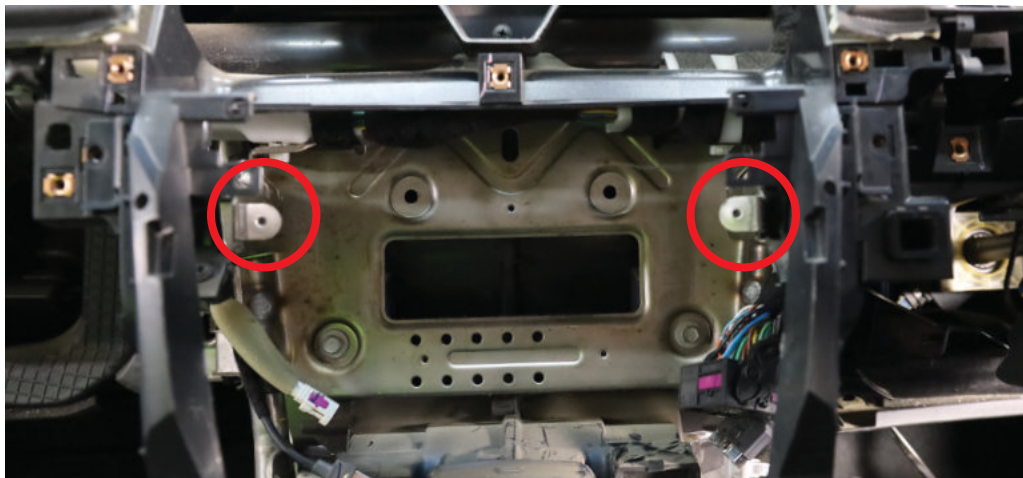

Ancillary support bracket on drivers side

Attach the support bracket using a screw from the cage removal process



Adding ancillary support brackets

Ancillary support bracket on passenger side

Attach the support bracket using a screw from the cage removal process

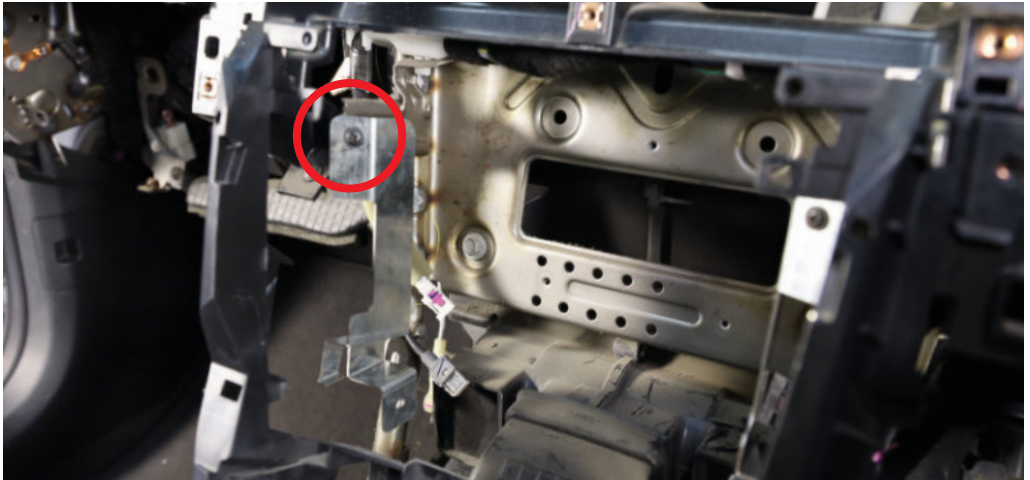

Finished result

For the correct position of the support brackets see the image below



Factory head unit disassembly

Removing factory vents (FP9550GK)

Place the factory head unit on face down on a soft surface. Remove the factory vents by removing 4 screws underneath and 1 screw on top of the vent.

This step not required for FP9550BK model.

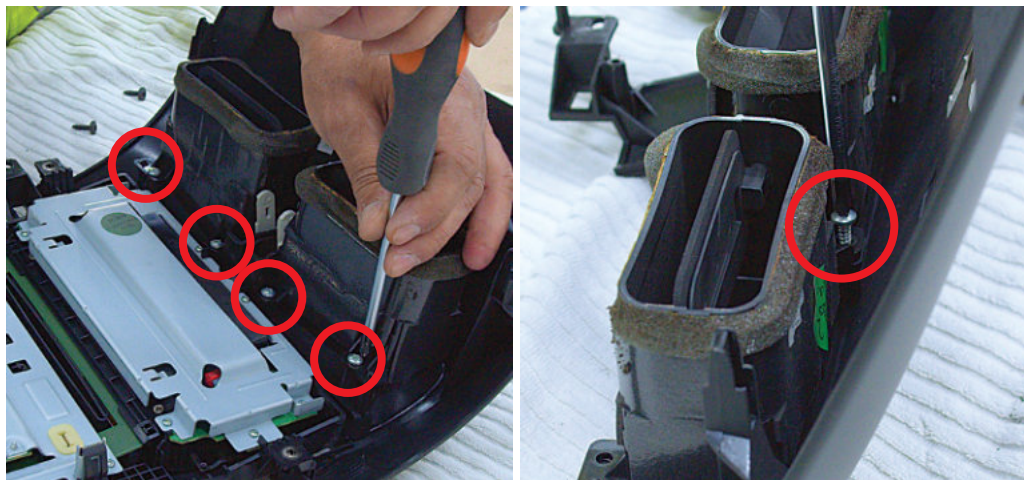

Removing factory face panel

Remove the 3 screws holding the face panel in place

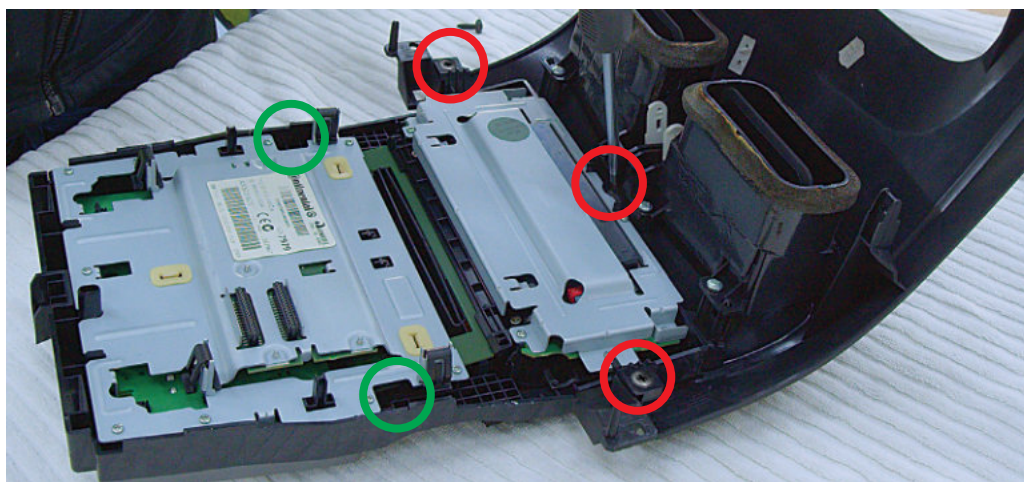

NOTE for FP9550BK models

This model has 2 additional screws on the factory panel (circled in green).

Facia Kit assembly

Installing and aligning your head unit

Place the head unit into the mounting bracket and loosely attach with screws on either side. Adjust the head unit to the desired depth before tightening the mounting screws on both sides.

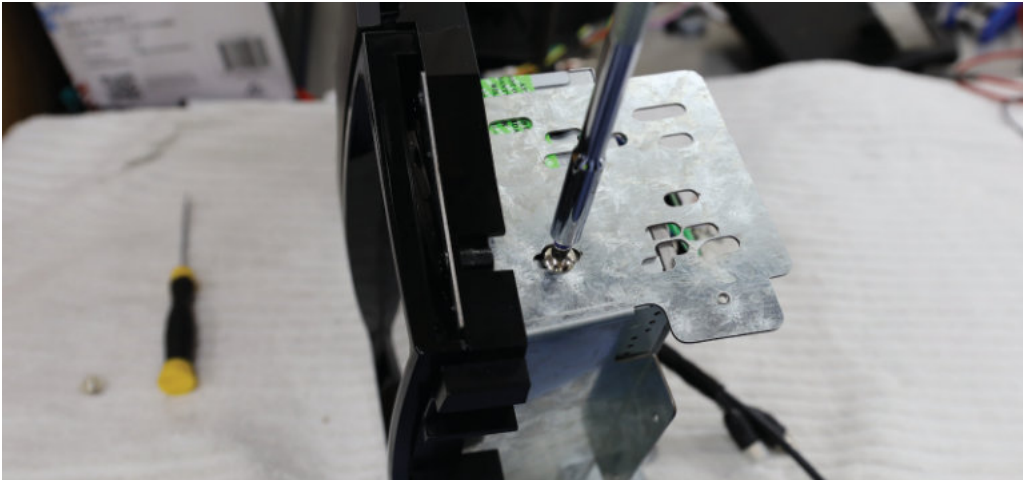

Attaching facia to factory top panel

When joining the 2 pieces together make sure the tabs on both align correctly before screwing into place

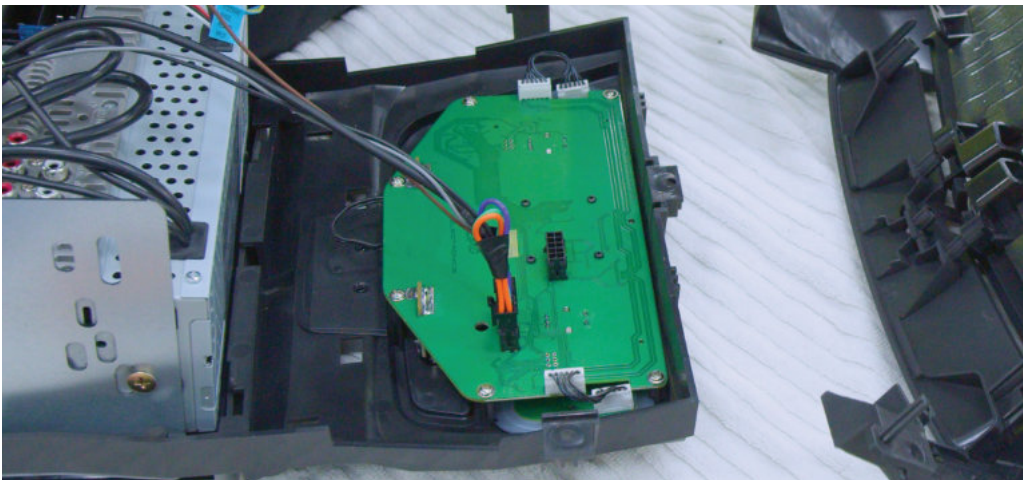

Facia Kit assembly

Aligning the tabs

The two tabs slot into the space provided assuring correct alignment

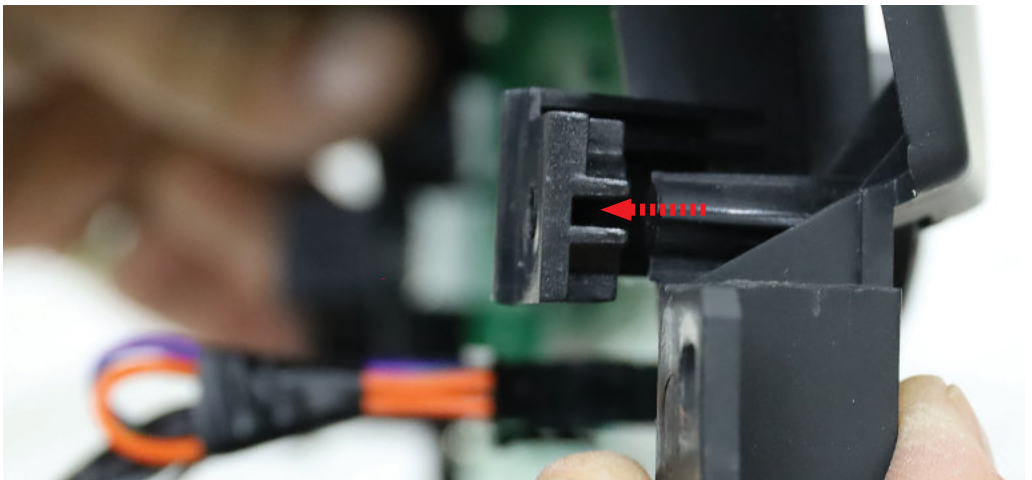
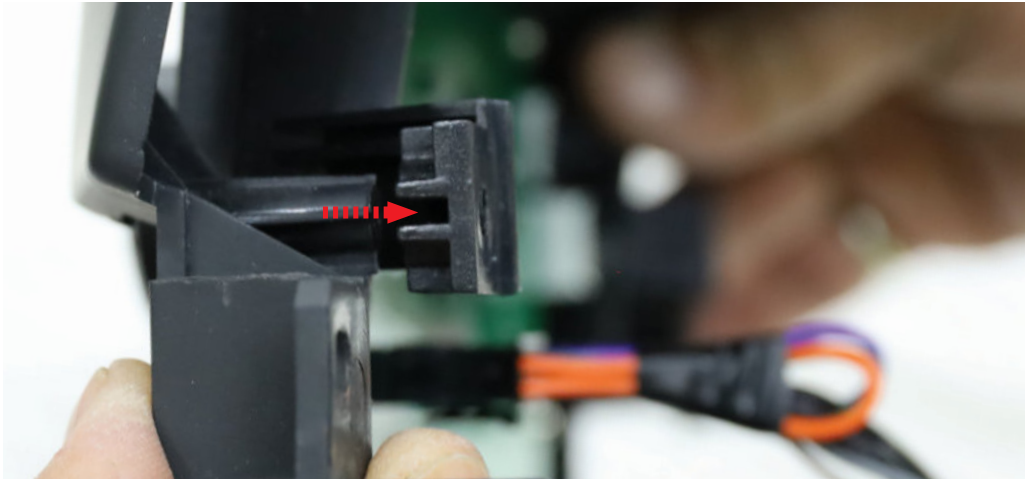

Facia Kit assembly

Attaching facia to factory top panel

Replace the 3 screws back into position on the top and two sides

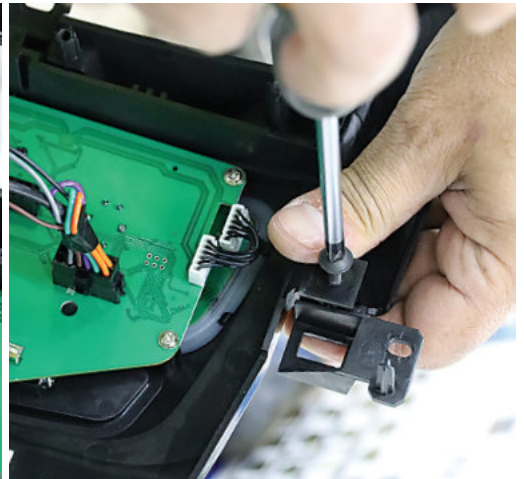
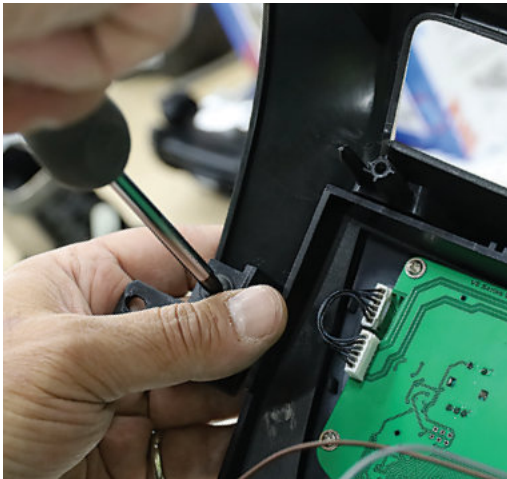

Facia Kit assembly

Re-attaching factory vents

Replace the 5 screws back into position on the top and bottom of the vents

This step not required for FP9550BK model.

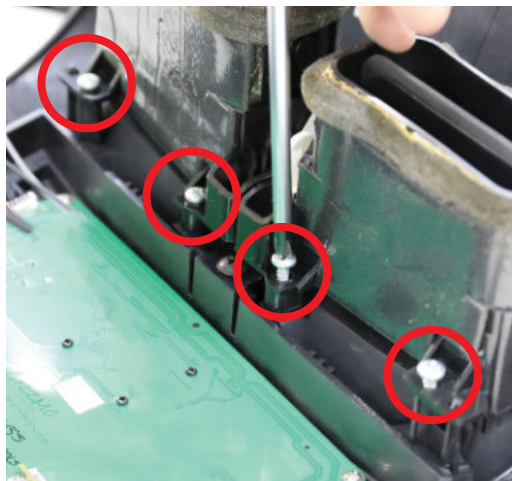

Connecting to head unit

Depending on the brand of head unit connect the 3.5 mm connector or single wire of the patch lead. (Refer to the SWC patch harness configuration page 55 of this manual). Connect the 12 pin plug to the circuit board.

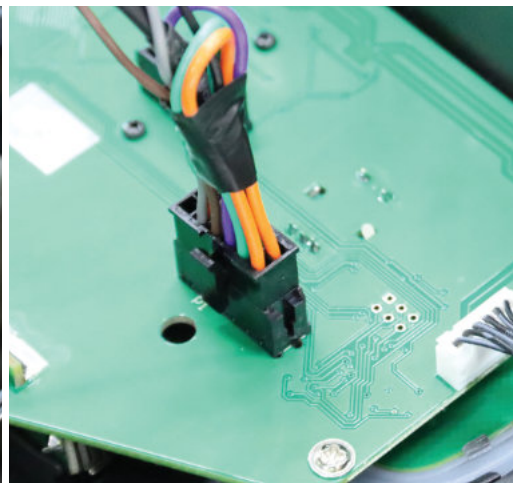

Connecting to head unit

Attach the reverse camera lead to the head unit (if applicable). Attach the antenna adapter to the head unit and vehicle.

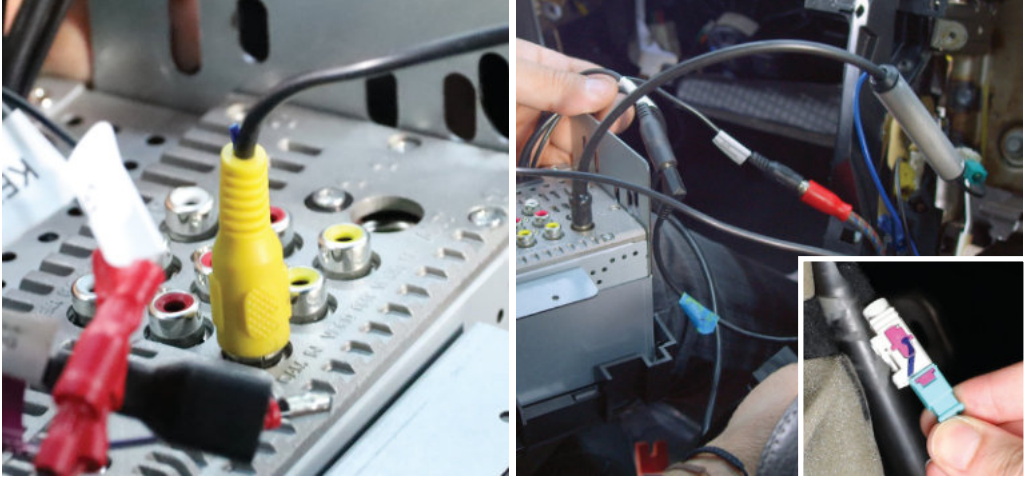

Attach the reverse, park brake and VSS cables (if available). Attach the factory USB retention cable located on the passenger side. The factory microphone can also be used with a 3.5mm jack or 2.5mm adaptor (if applicable for your head unit/not supplied).

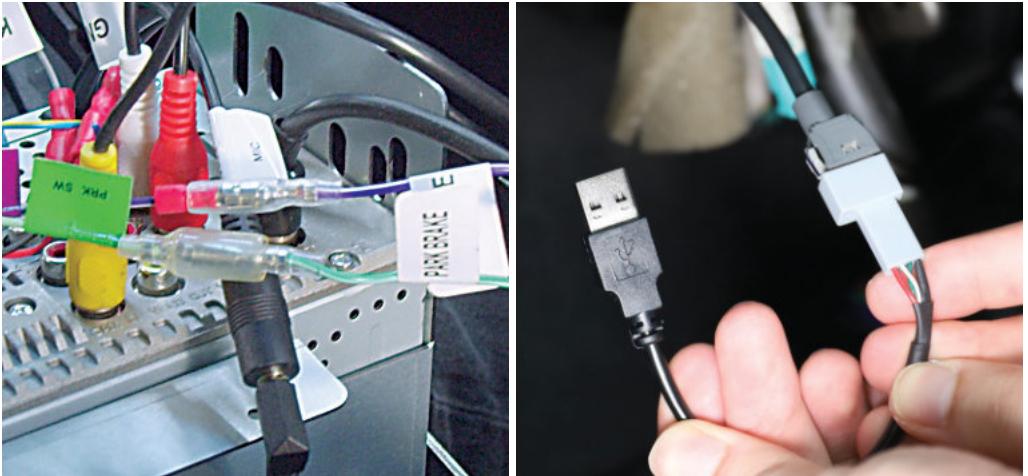

Main Harness Installation

Connect an Aerpro APP series (brand specific) secondary harness (sold separately) and a patch lead to the aftermarket unit. Connect to ISO plugs in main harness and connect to module. **NOTE: It is important to connect brand specific or correctly modified universal patch lead to module before powering up**

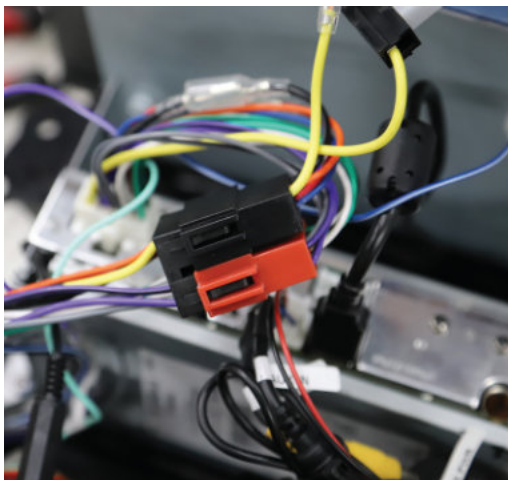
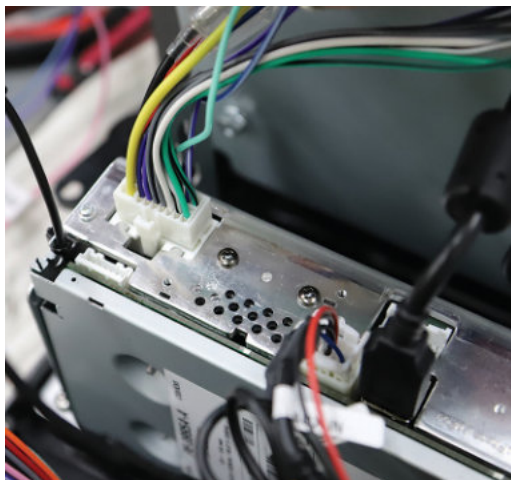

ISO standard head units

For this installation we used a GRUNDIG head unit which is ISO standard, thus a secondary harness was not required.

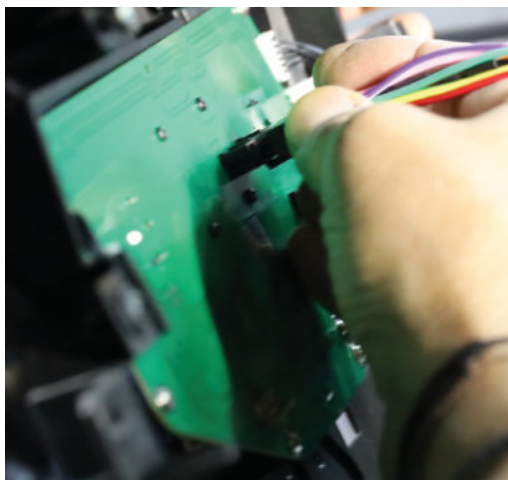
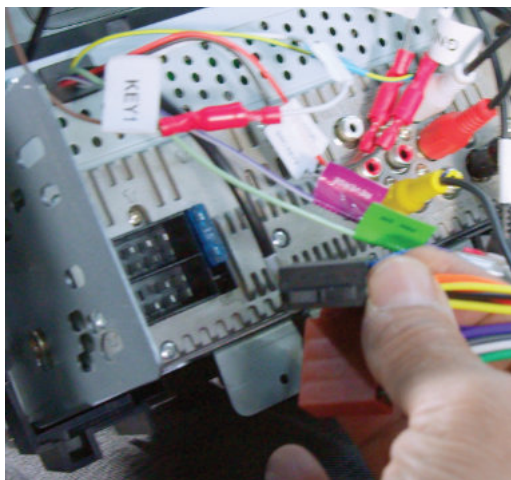

Main Harness Installation

Connecting to vehicle quadlock

Connect the main harness into the vehicles quadlock last, once all other connections are complete. This allows the system to correctly configure the HVAC & SWC. Loosely place the completed fascia into the dash to test functionality.

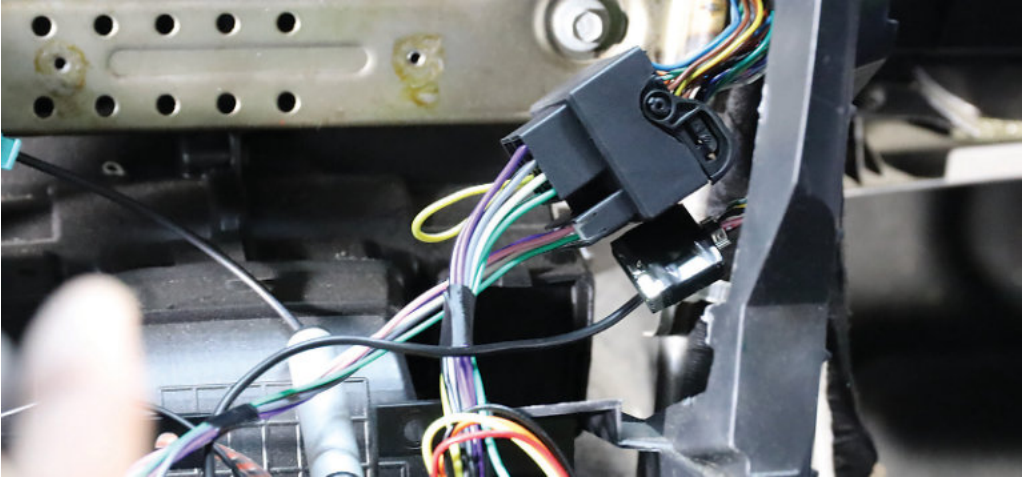

Testing the head unit & HVAC

Place the bottom of the fascia behind the plastic trim to temporarily hold in position. Turn on the vehicle ignition to test head unit audio and all HVAC controls are working correctly before starting to securing the fascia into the dash.

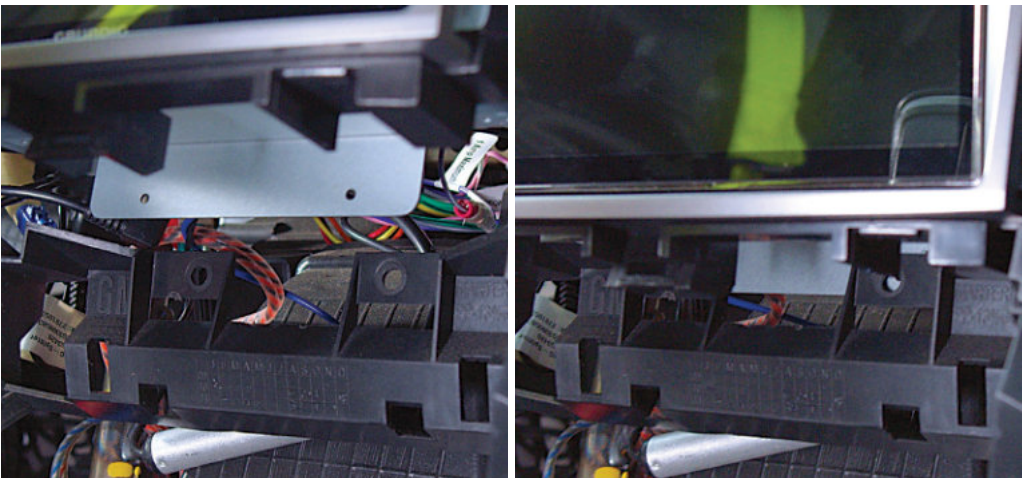

Facia Kit assembly

Once all of the functions have been tested, screw in the top section using the 2 screws retained earlier.

FP9550GK



FP9550BK



Facia Kit assembly

Screw in the bottom section using the 2 screws retained earlier.

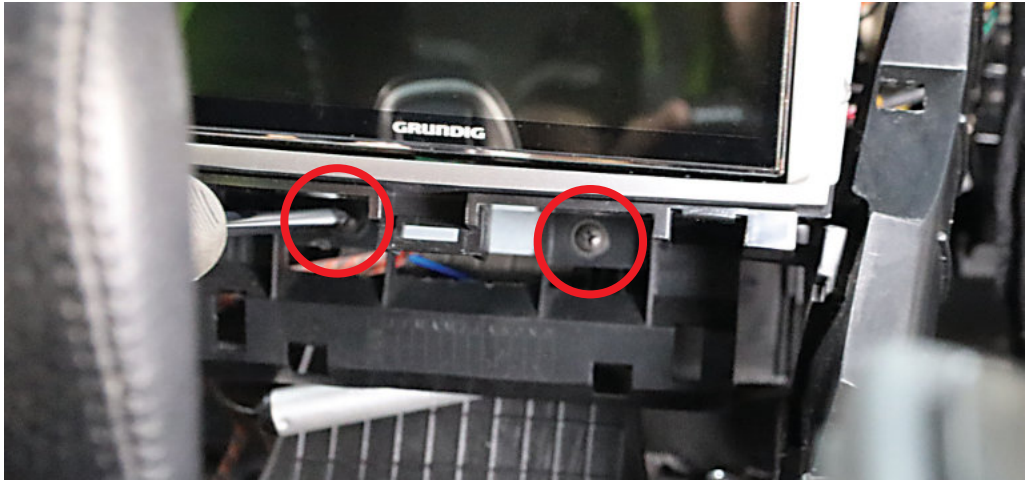

Attach the ancillary support brackets to the headunit bracket using the 2 of the screws retained earlier from the removal of the cage.



Reassemble in the reverse order to the disassembly to finish the installation

Product structure

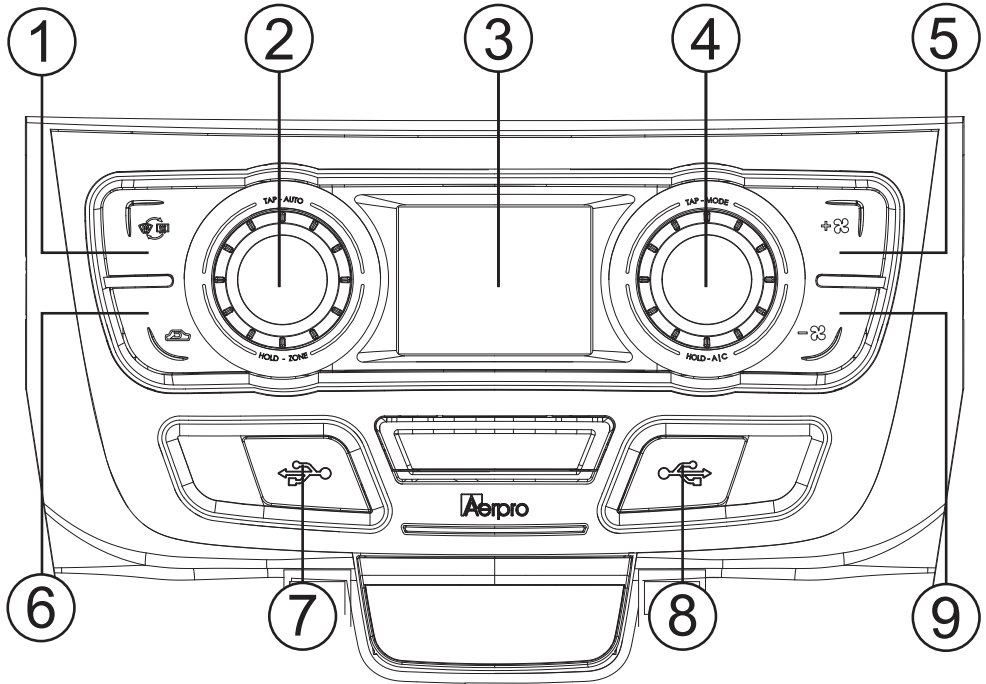

- | | |
|---|-----------------------------------|
| 1. Front/Rear demister air button | 6. Recirculated air on/off button |
| 2. Left rotary dial button (Rotate, Tap, Hold) | 7. USB charging and sync port |
| 3. LCD display information screen | 8. USB charging and sync port |
| 4. Right rotary dial button (Rotate, Tap, Hold) | 9. Fan speed DOWN |
| 5. Fan speed UP | |

Screen display

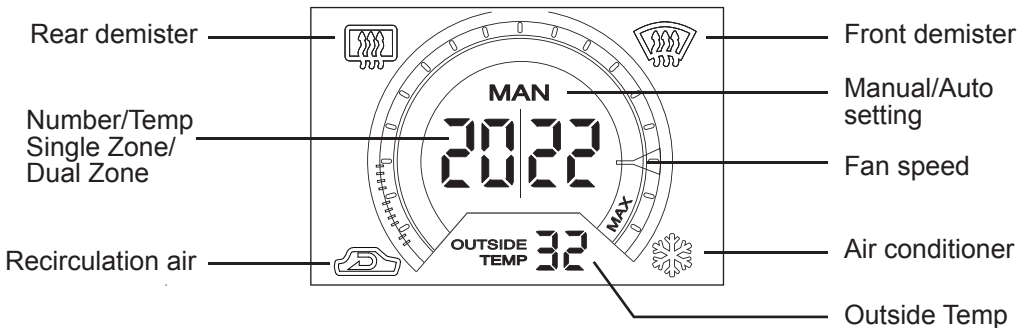

Functions



Turning air-conditioning ON/OFF

Once powered up, **press and hold** the right rotary dial button for 3 seconds until you hear a click sound. Once you release your finger the air-conditioner icon (Snowflake) illuminates. **Press and hold again to turn off.** When turning on the air-conditioner the system will remember your previous user settings.

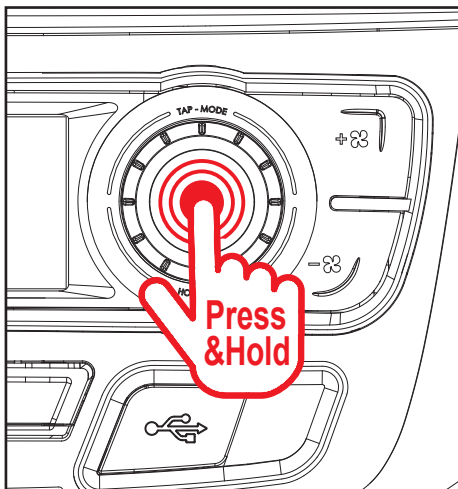

Positioning

To select different air positions in the vehicle tap the RIGHT rotary button. Positions are for the Head/Feet, Chest, Chest/Feet and Feet (See icons below). Selecting Head/Feet will automatically turn on the AC.

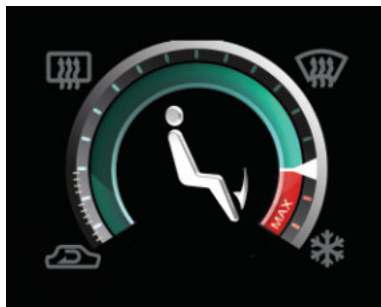
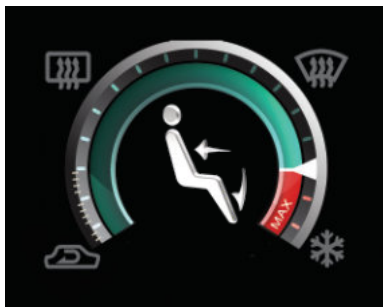
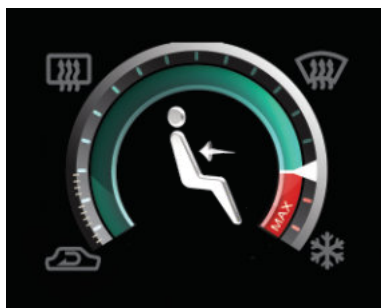
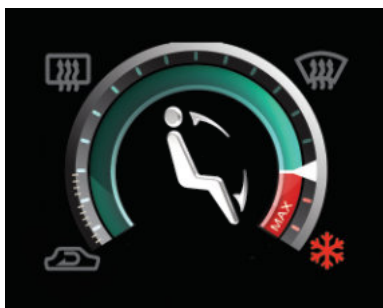
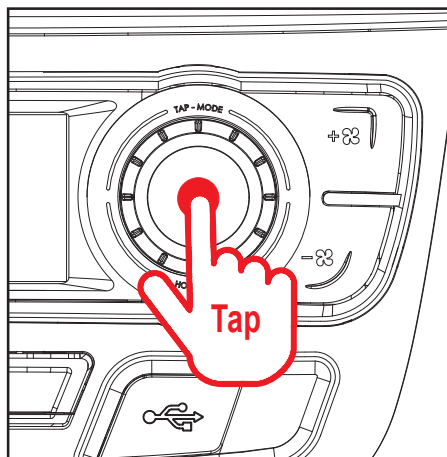

Functions

Recirculation/Air Passthrough button

Tap this button to cycle between Recirculation and Air Passthrough.
The corresponding icon will illuminate.

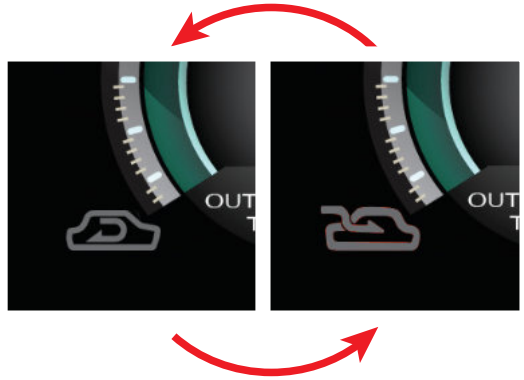
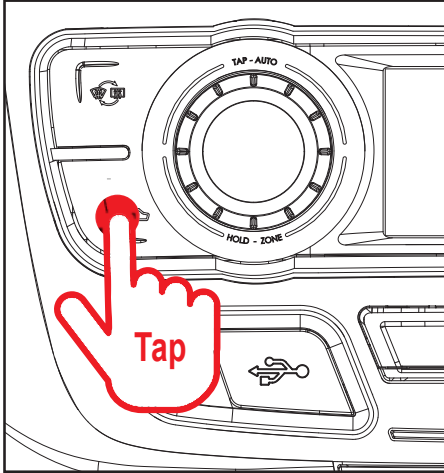

Functions

Front/Rear demister button

When air-conditioner is turned on tap this button to active Rear Demister or hold this button to activate the Front Demister.

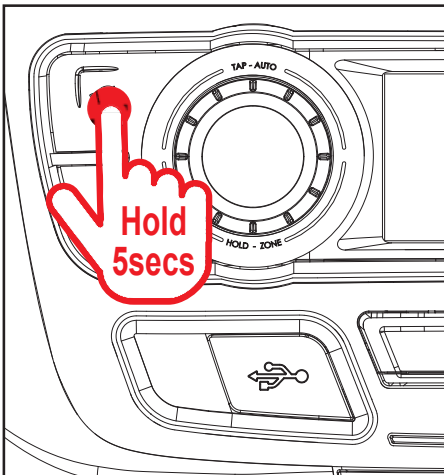
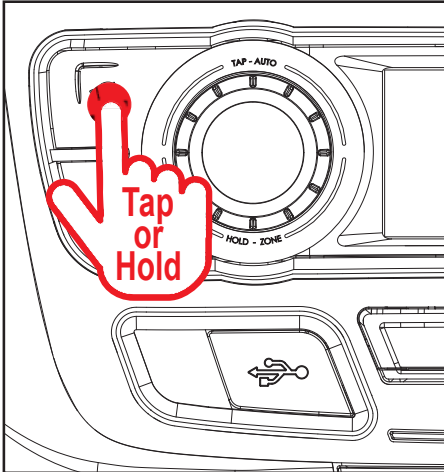

Re-Calibrating your HVAC System

In the case that you may need to re-calibrate your heater valves or ducting positions. For example, your vents do not pass air through the correct vents or hot/cold does not feel correct.

Press and hold the Front Demister button for 5 seconds or more until you hear the actuators in the car begin to re-calibrate. 4 x chimes will sound to confirm.

NOTE: Turning on Front Demister will automatically turn on A/C.

Functions

Fan speed

To adjust the fan speed tap on either of the two right buttons.

Top to increase fan speed and Bottom to lower fan speed.

NOTE: When the fan is set at 'Zero', the cars air circulation will change to pass through.

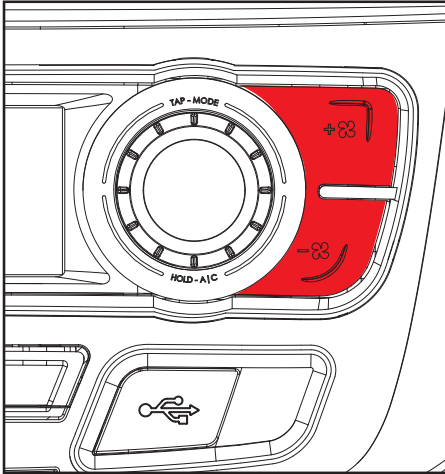

Air-conditioner temperature

Turn the right rotary dial to the left or right to lower and raise the air-conditioner temperature. C is the lowest, H is the highest. Numeric values range from 17°C to 30°C.

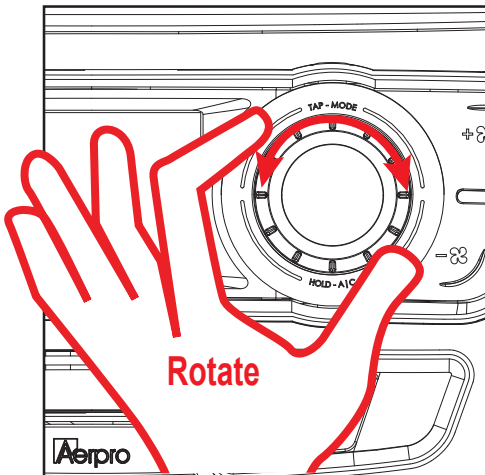

Functions

Automatic climate control

To activate auto climate mode, tap the left hand rotary dial and then set the target temperature by rotating the right hand rotary dial to the desired level. The fans speed, the vent temperature and the air flow direction is fully automatic and will adjust itself based on what it needs to get to the required level.

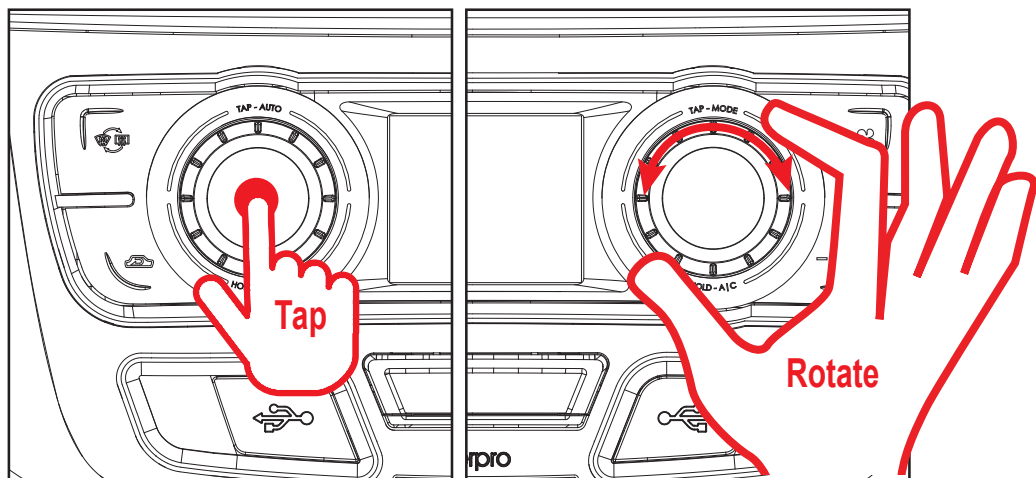

The temperature can be set between **16°C** and **31°C** when in **Climate Mode**.

NOTE

When the temperature is set to **C** or **H**. The **AUTO** symbol will turn off. This indicates the system will be running full **COLD** or full **HOT**.

Functions

Automatic climate control continued

When in Auto mode (SZ or DZ), the system is equipped with 3 levels of fan speeds. **Fan LOW**, **Fan MID** and **Fan HIGH**.

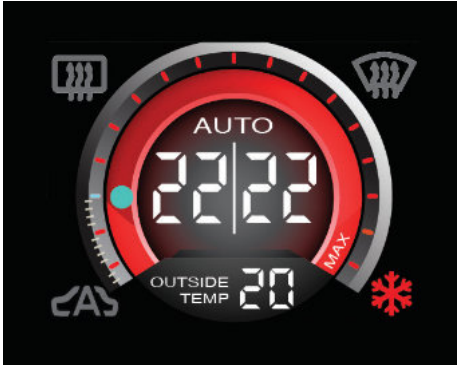

Fan LOW



Fan MID



Fan HIGH

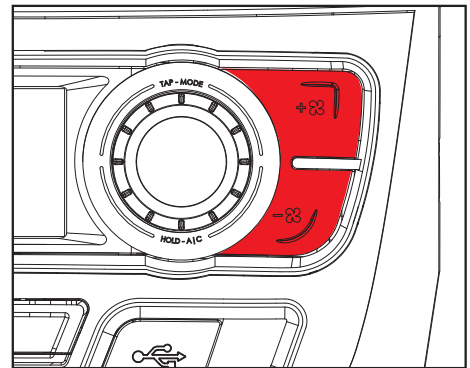

To adjust the levels use **Fan Up** and **Fan Down**

NOTE: *If you change the vents while in Auto Climate, the vents will change, however the fan will remain on AUTO (AUTO Symbol will turn off).*

If you change the **Air** speed above **FAN HIGH** or **FAN LOW** while in Auto Climate, the system will revert back to manual fan mode.

Functions

Single Zone

Holding the **LEFT** rotary dial will activate Single Zone. The Dual Zone temperature display will change to a Single Zone temperature display.

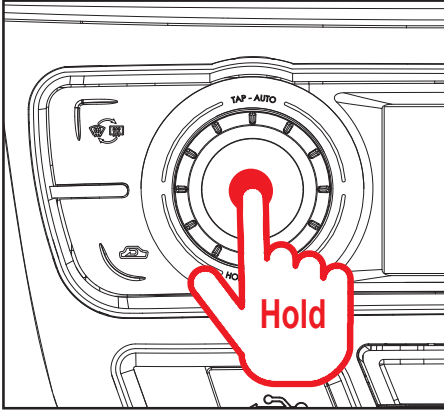

Adjusting Temperature

In Single Zone Mode the right rotary dial adjusts the temperature. Adjusting the left rotary dial will revert the system back to Dual Zone. Allows for the passenger temperature to be adjusted independently from the drivers side temperature.

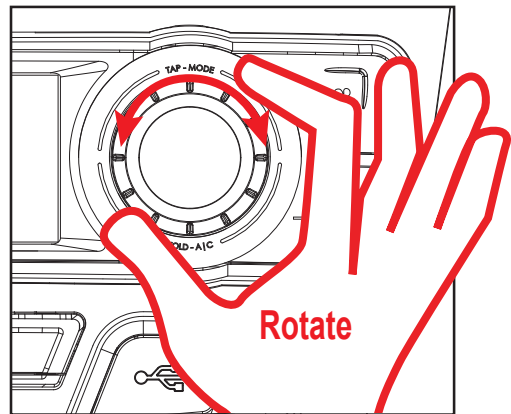
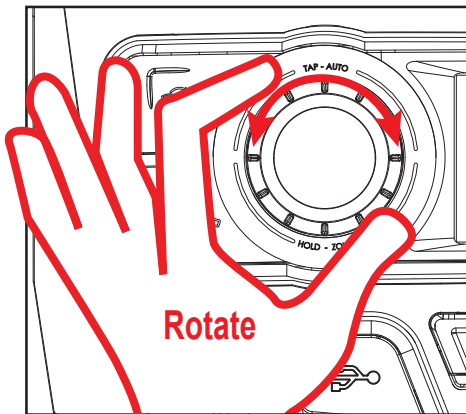

Functions

Dual Sync

When the **Dual Zone** is activated, the **Driver** and **Passenger** temps will be in sync. While they are in sync, both temps can be adjusted by the drivers dial.

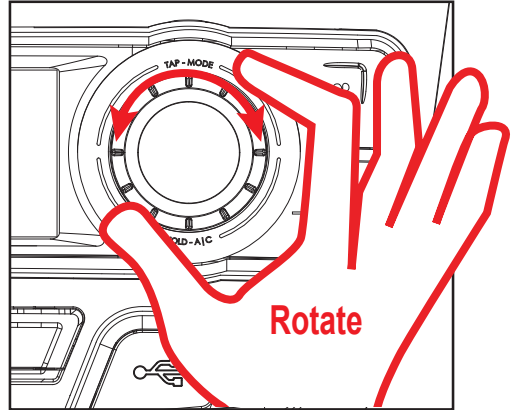

Dual Sync

When the **LEFT** rotary dial is rotated, the passenger temp will be adjusted. Once this is done, **Dual Sync** will turn off and both temps can be adjusted independently.

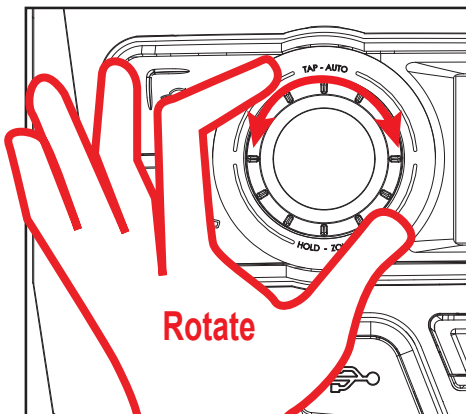

Functions

Anti-Pollution Mode

Anti-Pollution mode will automatically switch between Passthrough and Re-Circulation based on the vehicles speed. This is to avoid the vehicle drawing in unwanted fumes when travelling at low speeds.

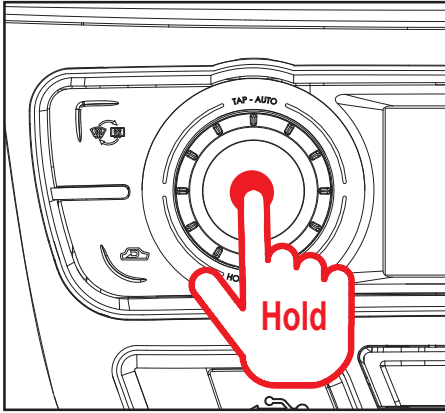

Activating Anti-Pollution Mode

To activate Anti-Pollution Mode, hold the passthrough button for 5 seconds then release. The screens symbol will change as shown.

To deactivate Anti-Pollution Mode, hold the passthrough button for 3 seconds, the release until you hear 4x Chimes, at which point the symbol will change back to normal.



Functions

Steering Wheel Control of the HVAC

Tap the left hand scroll wheel to control your HVAC via the left and right scroll wheels on your steering wheel.

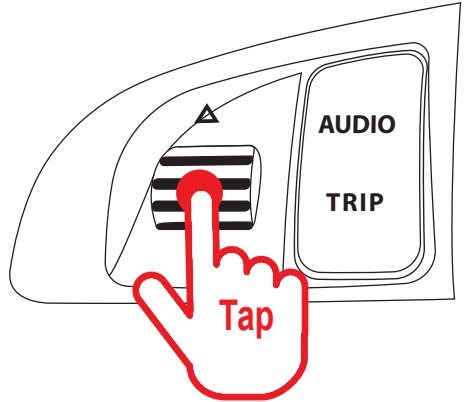

Single Zone

When in Single Zone the Left scroll wheel controls the fan speed and the Right scroll wheel controls temperature.

Dual Zone

When in Dual Zone the Left and Right scroll wheels control the temperature settings. Left for Passenger temp and Right for Drivers temperature.

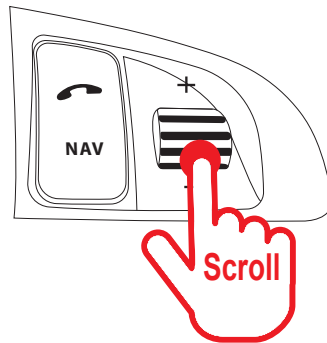
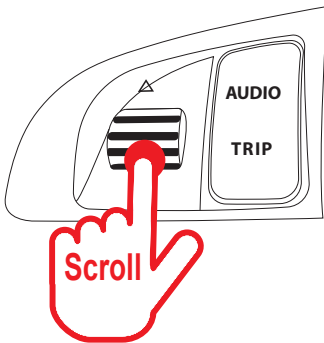

After '5' seconds of inactivity. The steering wheel controls will revert back to the aftermarket stereo and functionality will continue as normal

***NOTE* If no Headunit patch lead is present. The SWC will default to climate controls**

Functions

Left scroll wheel

Use the left scroll wheel to go up and down through audio tracks and radio stations.

Audio button

Press to select audio source.

Trip button

Press to access centre cluster settings.

Phone button

- Single press to answer a call
- During a call, single press to place the call on hold
- Long press to hang up

Nav button

No longer supported.

Right scroll wheel

Use the right scroll wheel to adjust the volume up and down.

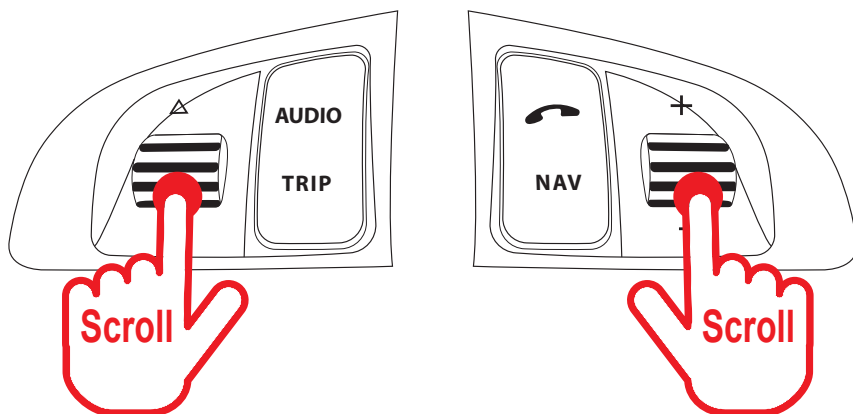

Functions

Parking Sensors

Parking sensors are retained if your vehicle had them fitted from factory. The screen will automatically display the parking sensors when the vehicle is in Reverse or if the vehicle is travelling less than 15km/h.

Front Sensors (When in Drive)

The Front sensors are displayed at the top of the screen. There are 3 sections to indicate the Left, Middle and Right of the Front of the vehicle with each having 4 levels of sensor warnings displayed. This indicates how close to a collision the vehicle is.



Rear Sensors (When in Reverse)

The Rear sensors are displayed at the bottom of the screen. There are 3 sections to indicate the Left, Middle and Right of the Rear of vehicle with each having 4 levels of sensor warnings displayed. This indicates how close to a collision the vehicle is.



Display Example

FRONT



REAR



Resetting the system

In the case of the system locking up or not functioning correctly, the unit can be reset to factory settings.

Press & hold both left & right rotary knobs at the same time.

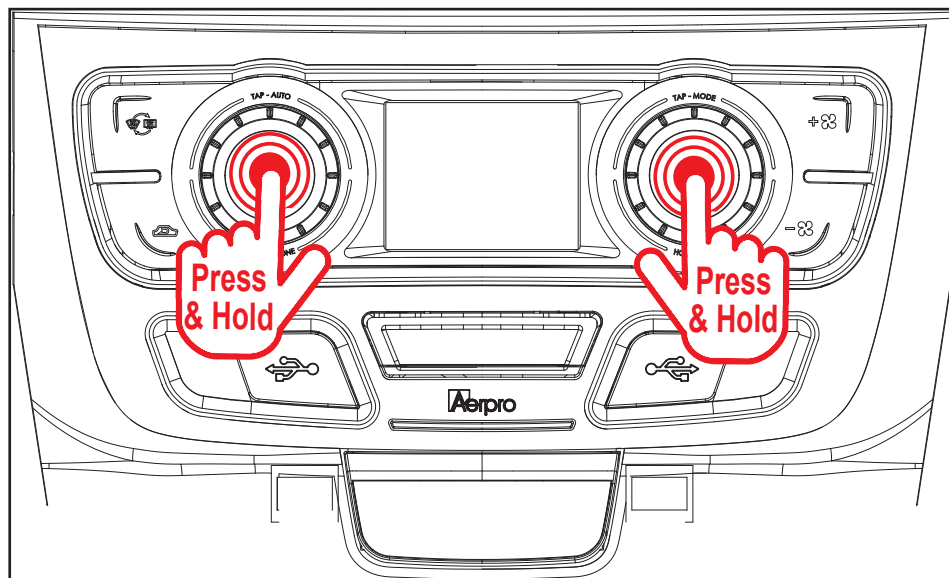

Wiring diagram

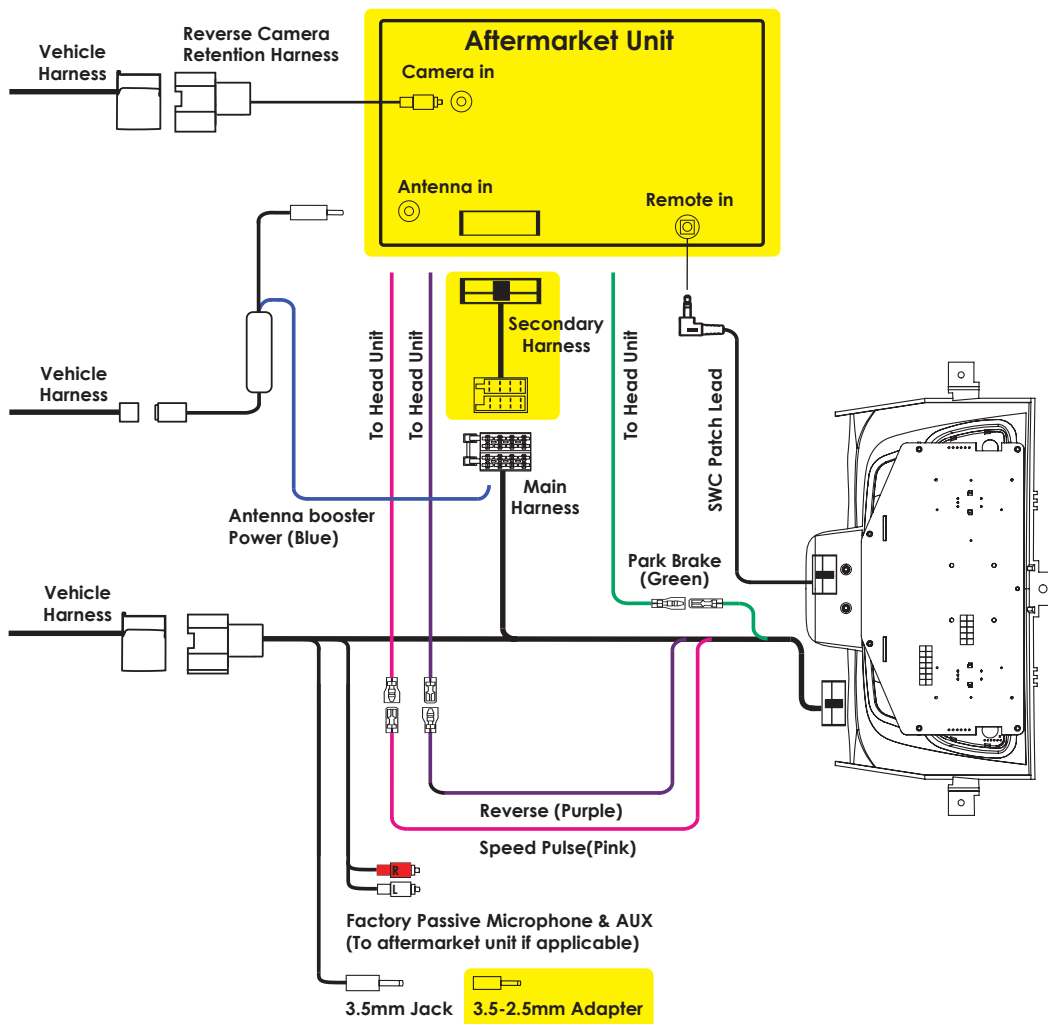

**Highlighted Yellow Not Included
(Sold Separately)**

SWC Patch Harness Configuration

For best results or to reset the control module with a new brand, please make modifications to the patch lead first, before connecting to the steering wheel control module and before powering the module up.

Use 3.5mm Jack for these Head-units

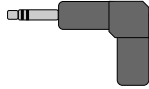

ALPINE
Cut Green Link

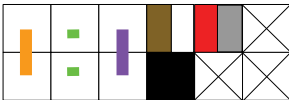

CLARION
Cut Purple Link

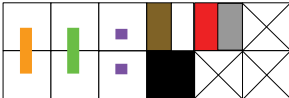

PIONEER
No cutting required

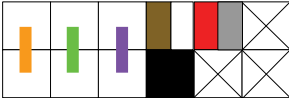

SONY
No cutting required



Use Key 1 Bullet terminal for these Head-units



Kenwood
Cut Orange & Green Wire

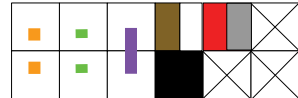

JVC
Cut Green & Purple Link

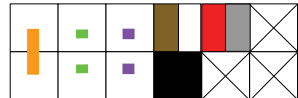

Zenec
Cut all 3 wires, solder Orange and Green together as shown



Use KEY 1, KEY 2 and GND Bullet terminals for Self Learn Head-units

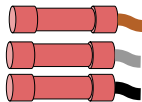

Self Learn Head-units
No cutting required

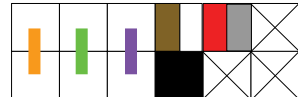

For SONY AV Head Units With Phone Pickup

We have added an alternative patch lead configuration to allow newer Sony units to work with the phone pickup button (model dependant-not all Sony units have this feature). Previously the Sony used the Pioneer/Sony config but if this is not working then changing to this new config should allow the phone button to work. PLEASE NOTE: Remove power from the Aerpro kit (unplug main quadlock plug) before changing patch lead configurations. This will allow the kit to reset its programming.

Alternate Sony Programming
Cut Orange & Purple Wire

Use 3.5mm Jack

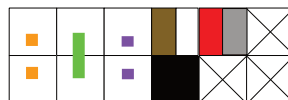
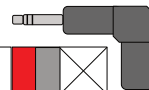

Technical assistance

If you need assistance setting up or using your Aerpro product now or in the future, call Aerpro Support. Australia

TEL: 03 – 8587 8888

FAX: 03 – 8587 8866

Mon-Fri 9am – 5pm AEST

Please retain this user guide for future reference.

If you would like to find more information on this product or download a digital copy of this manual, please visit the <https://aerpro.com> website and search for your model. An installation video is also available on our website.

This manual is considered correct at time of printing but is subject to change. For latest manuals and updates refer to the website.

Copyright © 2023 by TDJ Australia

All rights reserved. No part of this publication may be reproduced, distributed, or transmitted in any form or by any means, including photocopying, recording, copying or other electronic or mechanical methods, without the prior written permission of the author.

